

**Introduction to the
Accessibility Standards**

for the Built Environment

Presented by
Jennifer Skulski
Skulski Consulting LLC
(317) 408-4427
jennifer@skulskiconsulting.com
www.accessibilitymanagementnews.com

2024 Skulski Consulting LLC

1

Permission for Individual Educational Use

The following presentation contains content that is either public domain or the intellectual property of [Skulski Consulting LLC](#). Permission is granted to the training participant to use the document as a learning aide for professional development. No form of this document may be distributed to other individuals or agencies, reproduced or used by other agencies, businesses, consultants, or competitors; reproduced for presentations, training, or marketing; or any other such activities, without the express written consent of Skulski Consulting LLC.

Disclaimer

The sites or features represented in the following document, in some instances, may not meet the minimum accessibility standards and guidelines under the Americans with Disabilities Act.

2024 Skulski Consulting LLC

2

But first...

Let's talk about the [ADA Title II](#) and the [Program Access Standard](#)

2024 Skulski Consulting LLC

3

Americans with Disabilities Act

Program Access

§35.149
No qualified individual with a disability shall, because a **public entity's facilities** are inaccessible to or unusable by individuals with disabilities, be excluded from participation in, or be denied the benefits of the services, programs, or activities of a public entity, or be subjected to discrimination by any public entity.

2024 Skulski Consulting LLC

6

Americans with Disabilities Act

Program Access

§35.150
A public entity shall operate each service, program, or activity so that the service, program, or activity, **when viewed in its entirety**, is **readily accessible to** and **usable by** individuals with disabilities.

2024 Skulski Consulting LLC

7

Program Access & Program Spaces

When **viewed in its entirety***,
can visitors participate and
gain the benefits of the program?

2024 Skulski Consulting LLC

8

Accessibility Standards

- ADA Title II Regulations
 - https://www.ada.gov/ada_title_ii.htm
- 2010 ADA Standards for Accessible Design
 - <https://www.access-board.gov/ada/>
- Alabama Building Code ⇔ 2021 International Building Code (IBC)
 - A117.1 – Accessibility Committee
 - Chapter 11 – Accessibility
 - <https://codes.iccsafe.org/content/IBC2021V2.0>

9

Standards Development

- Purposed to meet the needs of a population
- Minimums “the worst you can do”
- Research
- Technology

10

Early Research

- Dr Timothy Nugent
- Graduate student and later Professor of Rehabilitation Education, University of Illinois
- Research on anthropometrics and environmental needs of wounded veterans and people with disabilities
- Established first college-level wheelchair basketball team
- Nugent’s research findings contributed to the release of the first voluntary accessibility standards in 1961 by the American National Standards Institute (ANSI) known as A117.1 Accessible and Usable Buildings and Facilities, and later the Uniform Federal Accessibility Standards (UFAS) under the Architectural Barriers Act of 1968.

Photo courtesy of the University of Illinois Archives.

11

Accessibility Standards & Disability

Estimated 80% for mobility impairments, 9% for visual impairments, 9% for hearing impairments and 2% for cognitive impairments.

12

Functional Limitations

Physical & Mobility Impairments

<ul style="list-style-type: none"> • Arthritis • Cerebral palsy • Spinal cord injury • Head injury • Stroke • Loss of limb/digits • Parkinson’s Disease • Muscular Dystrophy • ALS 	Functional Limitations <ul style="list-style-type: none"> • Ambulation • Stamina • Balance • Reach • Manual dexterity / fine motor skills 	ABA-ADA Building Blocks <ul style="list-style-type: none"> • Clear width • Clear floor space • Ground/floor surfaces • Access routes • Reach ranges • Operable parts
---	---	---

13

Functional Limitations

Visual Impairments

<ul style="list-style-type: none"> • Glaucoma • Cataracts • Macular Degeneration • Diabetic Retinopathy 	Functional Limitations <ul style="list-style-type: none"> • Visual acuity • Visual processing • Orientation • Navigation 	ABA-ADA Building Blocks <ul style="list-style-type: none"> • Access routes • Protruding objects • Detectable warnings • Visual elements • Tactile elements • Audible elements
---	---	--

14

Functional Limitations
Hearing Impairments

- Heredity
- Infections
- Tumors
- Accidents
- Aging

Functional Limitations

- Acuity
- Frequency
- Auditory processing

ABA-ADA Building Blocks

- Amplification
- Visual alternatives
- Signage

2024 Skulski Consulting LLC 15

15

Functional Limitations
Cognitive Impairments

- Down Syndrome
- Autism
- Alzheimer's Disease
- Stroke
- Head injury

Functional Limitations

- Perception
- Conceptualization
- Processing
- Memory
- Problem solving

ABA-ADA Building Blocks

- Signage and pictograms

Designing Beyond the Standards
 Simple finishes and displays
 Low language loading
 Simple and cued sequences

2024 Skulski Consulting LLC 16

16

Enforcement

Federal Legislation

- Complain driven.
- Civil rights enforcement through federal designated agencies.
 - DOJ
 - DOT
 - HUD
 - DOE
- Private right of action.

State & Local Building Code

- Local code authority.
- Plan review can affect permitting.
- Non-compliant construction may delay occupancy.

2024 Skulski Consulting LLC 17

17

Significant Updates with Release of the 2010 ADA Standards for Accessible Design

- Harmonization of 1991/1994 ADAAG with revised numbering system following IBC
- Definitions
- Reach ranges
- Scoping for van accessible parking space
- Toilet compartments
- Safe harbor

2024 Skulski Consulting LLC 18

18

Falling Out of Harmonization

- 2009 ANSI A117.1 / 2012 IBC = harmonized with ADA.
- 2017 ANSI A117.1 Edition = stuff starts to change again.
- Examples where 2017 ANSI A117.1 Edition **EXCEEDS** the 2010 ADA Standards for Accessible Design
 - Accessible routes between stories. Section 1104.4 requires accessible route (e.g. elevator) to connect each accessible story and/or mezzanine.
 - Family or assisted use toilet rooms required in mercantile or assembly with 6 or more water closets required.
 - New spatial dimensions for clear floor space and turning space in new construction.
 - More.....
 - View webinar archive: Harmonization between the ADA Standards and the IBC/ANSI A117.1 (Nov. 2017) presented by Marsha Mazz, Access Board, and Kim Paarlberg, ICC. <https://accessibilityonline.org/ao/archives/110634>

2024 Skulski Consulting LLC 19

19

2017 ANSI A117.1
Clear Floor Space

Existing

48 min
1220

30 min
760

New

52 min
1320

30 min
760

2024 Skulski Consulting LLC 20

20

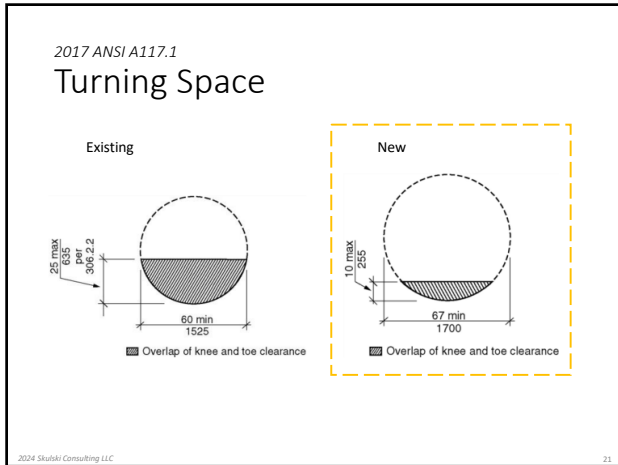

21

Falling Out of Harmonization

- 2017 ANSI A117.1 undergoing revision for 2023
- Other provisions under consideration:
 - Adult changing tables
 - Electric vehicle charging stations
 - Reach over counters
 - Walking and wheeled surfaces
 - Communications
 - Residential electrical receptacles

22

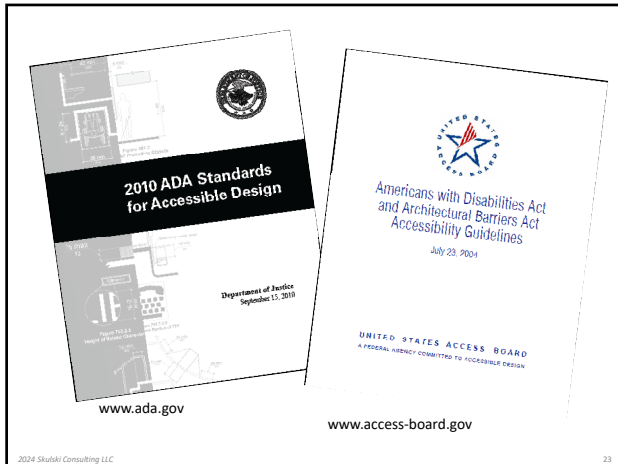

23

24

2010 ADA Standards for Accessible Design

<p>Chapter 1 Application & Administration</p> <p>Chapter 2 Scoping</p>	<p>Chapters 3-10</p> <p>Ch 3: Building Blocks</p> <p>Ch 4: Accessible Routes</p> <p>Ch 5: General</p> <p>Ch 6: Plumbing</p> <p>Ch 7: Communication</p> <p>Ch 8: Special Rooms & Spaces</p> <p>Ch 9: Built-in Elements</p> <p>Ch 10: Recreation</p>
--	---

25

Accessibility Standards Beyond the Built Environment

Chapter 10	Outdoor Areas	Other
<ul style="list-style-type: none"> • Amusement rides • Fitness equipment • Boat slips & boarding platforms • Sports Courts/Fields • Fishing piers & platforms • Golf • Miniature golf • Play areas • Swimming pools • Shooting positions 	<ul style="list-style-type: none"> • Outdoor facilities <ul style="list-style-type: none"> • Picnic areas • Viewing areas • Campgrounds • Trails • Beaches 	<ul style="list-style-type: none"> • Shared use paths • Public rights of way

26

Accessibility Standards
Status of Rulemaking

	ADA (Americans with Disabilities Act)	ABA (Architectural Barriers Act)	Best Available Info
Buildings	✓	✓	
Recreation Facilities	✓ (Chapter 10)	✓ (Chapter 10)	
Outdoor Developed Areas		✓ (Chapter 10)	✓
Public Rights of Way (PROWAG) (Sept 2023)	✓	✓	
Shared Use Paths (Sept 2023)	✓	✓	

2010 ADA Standards = 2015 IBC = 2012 ANSI A117.1

27

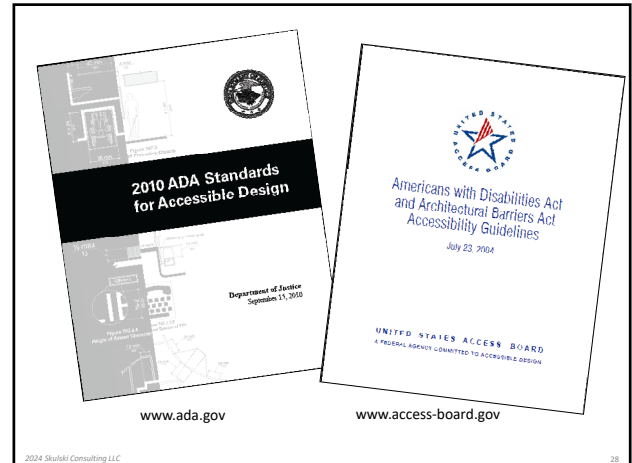

28

Chapter 1
Application & Administration

- 101 – Purpose
- 102 – Dimensions for Adults & Children
- 103 – Equivalent Facilitation
- 104 – Conventions
- 105 – Referenced Standards
- 106 – Definitions

29

Most Common Myth

- My building is “grandfathered” into the ADA
- Safe Harbor (28 CFR 35.151)(b)(4)(ii)(c)(Path of Travel)
 - If a public entity has constructed or altered required elements of a path of travel in accordance with the specifications in either the 1991 Standards or the Uniform Federal Accessibility Standards before March 15, 2012, the public entity is not required to retrofit such elements to reflect incremental changes in the 2010 Standards solely because of an alteration to a primary function area served by that path of travel.

30

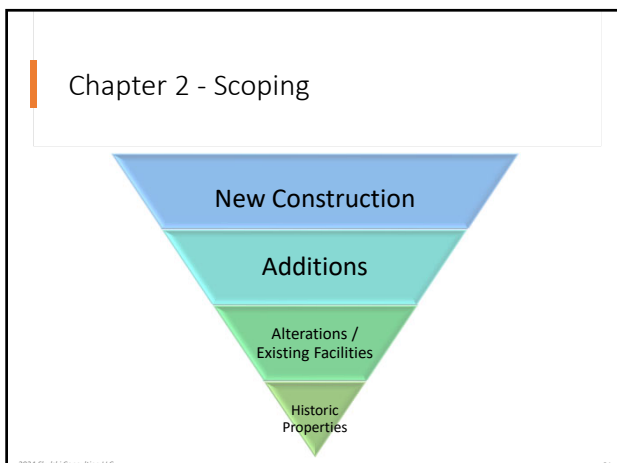

31

Application (201)

- All areas of newly designed and newly constructed buildings and facilities and altered or leased portions of existing buildings and facilities shall comply with these requirements.
 - State/ local gov't facilities
 - Places of public accommodation
 - Commercial facilities
 - Transportation facilities (DOT's 2006 Standards)
- Exceptions
 - Exempted structures/ spaces
 - Employee work areas
 - Partially scoped spaces

32

Existing Buildings & Facilities (202)

- Additions
- Alterations
- Primary Function Areas
 - Path of Travel – access route to primary function area, restrooms, drinking fountains, other amenities serving altered space.
 - “Alterations made to provide an accessible path of travel to the altered area will be deemed disproportionate to the overall alteration when the cost exceeds 20% of the cost of the alteration to the primary function area.” (28 CFR 36.403 (f)(1)).
- Qualified Historic Facilities

33

Historic Properties (202.5)

- Must meet accessibility guidelines
- Exception
 - Where the State Historic Preservation Officer or Advisory Council on Historic Preservation determines that compliance with the requirements for accessible routes, entrances, or toilet facilities would threaten or destroy the historic significance of the building or facility, the exceptions for alterations to qualified historic buildings or facilities for that element shall be permitted to apply.
- Program access

34

General Exceptions (203)

- Construction sites
- Raised areas (refereeing, judging, scoring, boxing, wrestling, diving platforms)
- Limited access spaces
- Machinery spaces
- Single occupant structures
- Detention & correction facilities
- Residential facilities
- Employee work areas (under ADA)
- Water slides
- Animal containment areas

35



36

Chapter 2 - Scoping

• 201 Application	• 216 Signs	• 230 Two-Way Communication Systems
• 202 Existing Buildings and Facilities	• 217 Telephones	• 231 Judicial Facilities
• 203 General Exceptions	• 218 Transportation Facilities	• 232 Detention Facilities and Correctional Facilities
• 204 Protruding Objects	• 219 Assistive Listening Systems	• 233 Residential Facilities
• 205 Operable Parts	• 220 Automatic Teller Machines and Fare Machines	• 234 Amusement Rides
• 206 Accessible Routes	• 221 Assembly Areas	• 235 Recreational Boating Facilities
• 207 Accessible Means of Egress	• 222 Dressing, Fitting, and Locker Rooms	• 236 Exercise Machines and Equipment
• 208 Parking Spaces	• 223 Medical Care and Long-Term Care Facilities	• 237 Fishing Piers and Platforms
• 209 Passenger Loading Zones and Bus Stops	• 224 Transient Lodging Guest Rooms	• 238 Golf Facilities
• 210 Stairways	• 225 Storage	• 239 Miniature Golf Facilities
• 211 Drinking Fountains	• 226 Dining Surfaces and Work Surfaces	• 240 Play Areas
• 212 Kitchens, Kitchenettes, and Sinks	• 227 Sales and Service	• 241 Saunas and Steam Rooms
• 213 Toilet Facilities and Bathing Facilities	• 228 Depositories, Vending Machines, Change Machines, Mail Boxes, and Fuel Dispensers	• 242 Swimming Pools, Wading Pools, and Spas
• 214 Washing Machines and Clothes Dryers	• 229 Windows	• 243 Shooting Facilities with Firing Positions
• 215 Fire Alarm Systems		

37

Chapter 2 Scoping

Accessible Routes (206)

- At least one accessible route shall connect accessible building or facility entrances with all accessible spaces and elements within the building or facility which are otherwise connected to a circulation path.
- Where required
 - Site arrival points
 - Within sites
 - Between stories
 - Spaces and elements
 - Specific spaces (i.e. restaurants, cafeterias, performance areas, press boxes, employee work areas, fishing piers, golf, play areas)

38

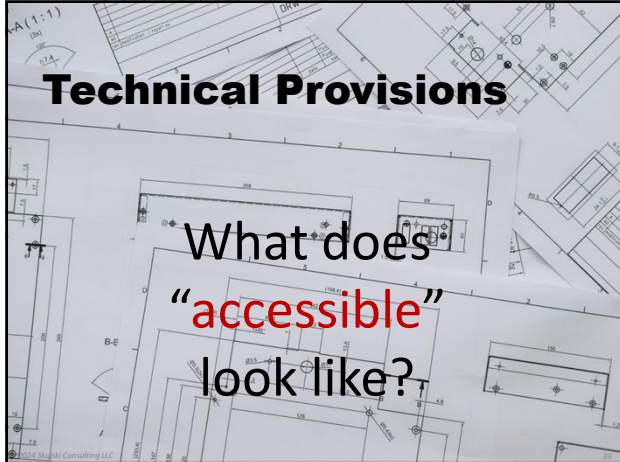

39

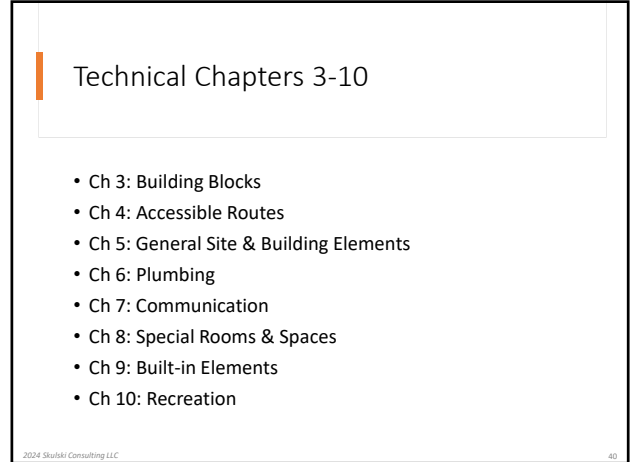

40

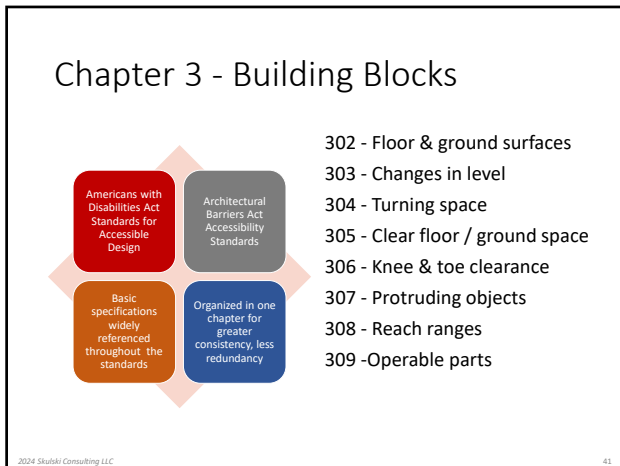

41

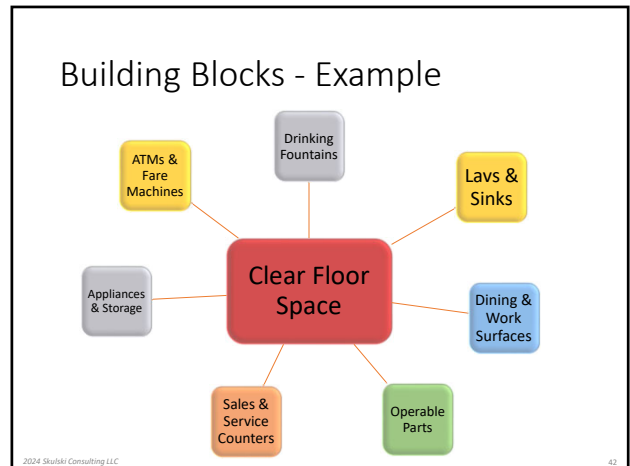

42



43

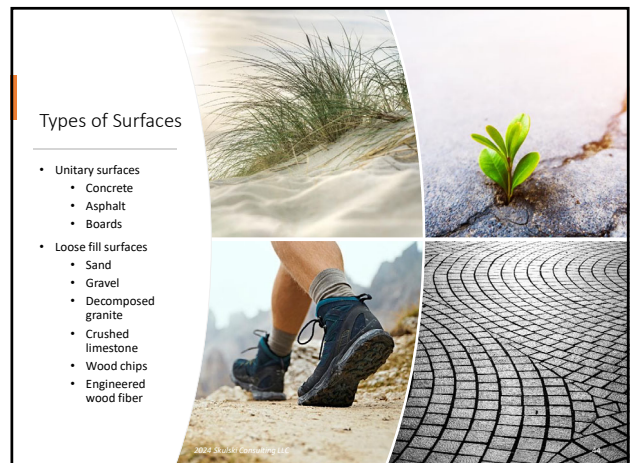

44

Chapter 3 Building Blocks
Floor or Ground Surfaces (302)

- Carpet
 - ½ inch max pile height (measured to the backing, cushion, or pad)
 - Texture: level or textured loop, level cut pile, or level cut/uncut pile
 - Firm backing, cushions, pads (avoid cushions/ pads for greater firmness)
 - Firm securement, edging to prevent rolling or buckling



2024 Skulski Consulting LLC 45

45

Sports Facilities

Exception example:

- Area of sport activity: the portion of a room or space where the play or practice of sport occurs.
- Accessible route to each area of sport activity.
- The area within the sports activity (court, field, etc) is exempt from firm, stable, and slip resistant surface provision.



2024 Skulski Consulting LLC 46

46

Chapter 3 Building Blocks
Floor or Ground Surfaces (302)

- Openings
 - Max ½" opening
 - Elongated opening should be perpendicular to path of dominant travel

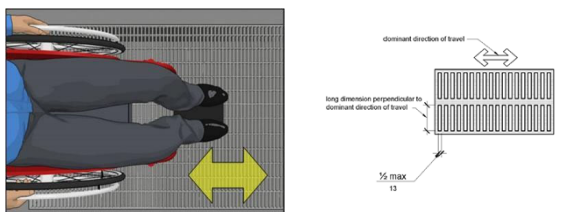

2024 Skulski Consulting LLC 47

47

Chapter 3 Building Blocks
Changes in Level (303)

- Changes in level max ¼"
- ¼" to ½" must be beveled

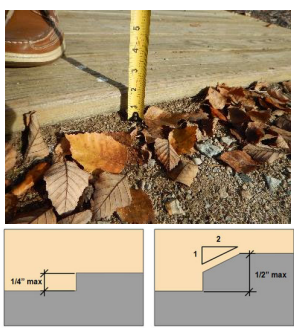

2024 Skulski Consulting LLC 48

48

Chapter 3 Building Blocks
Wheelchair Turning Space (304)

- 60" circular space OR
- 60" T-shaped space

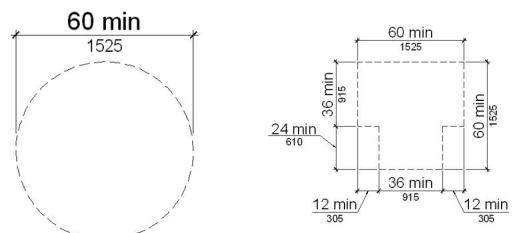

2024 Skulski Consulting LLC 49

49

Chapter 3 Building Blocks
Wheelchair Turning Space (304)

- Required at 180 degree turns around obstructions less than 48" long (unless route at least 42" wide)

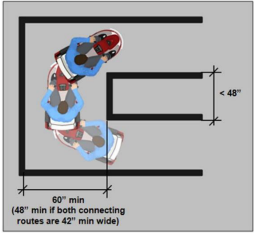

2024 Skulski Consulting LLC 50

50

Chapter 3 Building Blocks
Wheelchair Turning Space (304)

- Also required at
 - toilet and bathing facilities
 - dressing, fitting, and locker rooms
 - transient lodging guest rooms
 - dwelling units (all rooms on an accessible route)
 - patient bedrooms
 - holding and housing cells
 - saunas and steam rooms
 - raised courtroom stations served by ramps or lifts with entry ramps
 - certain recreation spaces (amusement ride load/ unload areas, fishing piers and platforms, play components, and shooting facilities)

2024 Skulski Consulting LLC 53

51

Chapter 3 Building Blocks
Wheelchair Turning Space (304)

- Turning space can overlap
- Overlap of circular space (25" max)
- Recommended: avoid overlap or limit to approx 12" (wheelchair space remains clear)
- Turning space can overlap other clearances; door can swing into turning space.

2024 Skulski Consulting LLC 52

52

Chapter 3 Building Blocks
Wheelchair Maneuvering Space

Wheelchair Maneuvering Space

<https://www.access-board.gov/images/videos/wcmaneuvering-captioned.mp4>

2024 Skulski Consulting LLC 53

53

Chapter 3 Building Blocks
Clear Floor or Ground Space (305)

- Minimum clear floor space 30" x 48"
- Minimum clear width 36"
- Can reduce to 32" (for a depth less than 24")
- Slope less than 1:48 or 2.08% in all directions

2024 Skulski Consulting LLC 54

54

Chapter 3 Building Blocks
Clear Floor or Ground Space (305)

- Required at operable parts and other accessible elements (e.g., drinking fountains, lavatories and sinks, counters, dining/ work surfaces, etc)

2024 Skulski Consulting LLC 55

55

Chapter 3 Building Blocks
Clear Floor or Ground Space (305)

- Forward approach
 - Required at dining/ work surfaces, drinking, lavatories, most sinks, urinals.
- Side approach
 - Specified/ usually provided at sales & service counters, beds, and most appliances.
- Either approach allowed at other elements.

2024 Skulski Consulting LLC 56

56

Chapter 3 Building Blocks
Clear Floor or Ground Space (305)

- Centering the clear floor space is only required at certain elements:
 - drinking fountains,
 - kitchen work surfaces,
 - washers & dryers.
- Additional space is required when the space is confined on three sides and is obstructed for more than half the depth, such as when elements are recessed in alcoves.

2024 Skulski Consulting LLC 57

57

Chapter 3 Building Blocks
Knee & Toe Clearance (306)

- Toe clearance
 - 9" above the ground
 - 17-25" depth
 - 30" width
- Knee clearance
 - 9-27" above the ground
 - 8-25" depth (depending on element)
 - 30" width

2024 Skulski Consulting LLC 58

58

Chapter 3 Building Blocks
Knee & Toe Clearance (306)

Required at

- drinking fountains
- lavatories & most sinks
- dining/ work surfaces
- sales & service counters
- other elements providing forward approach.

2024 Skulski Consulting LLC 59

59

Chapter 3 Building Blocks
Protruding Objects (307)

- Applies to each circulation path, not just the accessible route
- 4" max projection
- Cane detectable
 - Leading edge 27" max above floor
- Vertical clearance
 - 80" min height

2024 Skulski Consulting LLC 60

60

Chapter 3 Building Blocks
Protruding Objects (307)

- Applies to each circulation path, not just the accessible route
- 4" max projection
- Cane detectable
 - Leading edge 27" max above floor
- Vertical clearance
 - 80" min height

Protruding Objects

<https://www.access-board.gov/images/videos/protrudingobjects-captioned.mp4>

2024 Skulski Consulting LLC 61

61

Chapter 3 Building Blocks
Protruding Objects (307)

- Post-mounted objects
- Objects with leading edges 27- 80 inches high on posts/ pylons:
- 12 inch max protrusion into circulation paths.

2024 Skulski Consulting LLC 62

62

Chapter 3 Building Blocks
Protruding Objects (307)

- Example:
 - Signs
 - Trailheads
 - Information kiosks

2024 Skulski Consulting LLC 63

63

Chapter 3 Building Blocks
Reach Ranges (308)

- Unobstructed forward and side reach
- 15 inches minimum
- 48 inches maximum

2024 Skulski Consulting LLC 64

64

Chapter 3 Building Blocks
Reach Ranges (308)

- Obstructed forward reach
 - 48 inches maximum not to exceed 20 inch depth
 - Reduced to 44 inch max height for depth 20-25 inch max

2024 Skulski Consulting LLC 65

65

Chapter 3 Building Blocks
Reach Ranges (308)

- Obstructed side reach
 - 48 inches max height if depth is less than 10 inches
 - Reduced to 46 inch max height if depth exceeds 10 inches
 - Obstructions at side reaches are limited to a height of 34 inches.

2024 Skulski Consulting LLC 66

66

Advisory
Children's Reach Ranges
 By age group

Max. Reach
 44" (9 – 12 yrs)
 40" (5 – 8 yrs)
 36" (3 & 4 yrs)

Min. Reach
 20" (3 & 4 yrs)
 18" (5 – 8 yrs)
 16" (9 – 12 yrs)

2024 Skulski Consulting LLC 67

67

Chapter 3 Building Blocks
Operable Parts (309)

- Placed within reach range
- Operable with one hand
- No tight grasping, pinching, or twisting of the wrist
- Less than 5 lbs force to operate

2024 Skulski Consulting LLC 68

68

Chapter 4
Accessible Routes

- Accessible routes
- Walking surfaces
- Doors, doorways, gates
- Ramps
- Curb ramps
- Elevators
- Limited use / limited application elevators
- Private residence elevators
- Platform lifts

Site arrival points include accessible parking spaces and accessible passenger loading zones, public transit stops located on sites, and public streets and sidewalks.

An accessible route must connect site arrival points to each accessible entrance they serve.

Accessible routes must coincide with, or be in the same vicinity as, general circulation paths (§206.3).

If no pedestrian route onto a site is provided and site entry is by vehicle only, an accessible route from the site boundary is not required (§206.2.1, Ex. 2). Where a vehicular way does provide pedestrian access, such as a shopping center parking lot, an accessible route is required.

2024 Skulski Consulting LLC 69

69

Chapter 4
Accessible Routes (402)

- Slope not steeper than 1:20
- Cross slope 1:48 max
- 36" min width
- Can reduce to 32" for a length of 24" max

2024 Skulski Consulting LLC 70

70

Chapter 4
Passing Space (403.5.3)

- 36" min width
- 48" requires ambulatory person to twist to pass wheelchair user (ADAAG Advisory)
- 60" preferred
- Routes less than 60" require passing space intervals every 200 ft max

2024 Skulski Consulting LLC 71

71

Chapter 4 Accessible Routes
Doors & Doorways (404)

- Clear width 32" min
- Openings more than 24" deep require clear opening 36" min
- No projection into clear opening lower than 34" above finished floor (allowance for panic bar)
- Maneuvering clearance to approach & open door
- Dependent on
 - Push/Pull side of door
 - Hinge/Latch approach
 - Forward/Side approach

Alterations: latch side stop can reduce the clear width 5/8" max

2024 Skulski Consulting LLC 72

72

Chapter 4 Accessible Routes
Doors

- Operable parts such as handles, pulls, latches and locks mounted 34-48" above finished floor
- Interior doors
 - Opening force less than 5 lbs
- Fire doors
 - Minimum opening force allowable by the appropriate administrative authority

2024 Skulski Consulting LLC 73

73

Some State Building Code
Exterior Doors

- Exterior hinged doors must be designed so that such doors can be pushed or pulled open with a force not exceeding **8.5 lbs.**

2024 Skulski Consulting LLC 74

74

Chapter 4 Accessible Routes
Revolving Doors (404.3.7)

- Revolving doors, revolving gates and turnstiles shall not be part of an accessible route



2024 Skulski Consulting LLC 75

75

Chapter 4 Accessible Routes
Ramps (405)

- Routes with slopes exceeding 1:20 must meet the requirements for ramps
 - Handrails
 - Landings
 - Edge protection
- Max slope 1:12, 1:16 preferred
- Rise 30" max

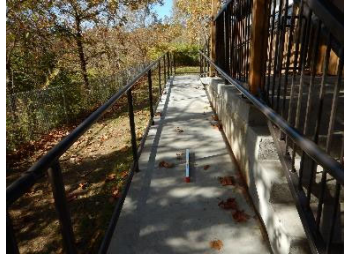

2024 Skulski Consulting LLC 76

76

Chapter 4 Accessible Routes
Ramps

- 36" min clear width
- Landings 60" long
- Landings where ramps change direction 60" x 60"
- 1:48 on landing
- Handrails & edge protection on both sides

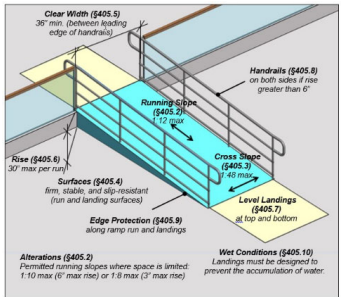

2024 Skulski Consulting LLC 77

77

Chapter 4 Accessible Routes
Ramps Exception (405.2)

- In existing sites, buildings and facilities ramps shall be permitted to have a running slope steeper than 1:12 complying with Table 405.2 where such slopes are necessary due to space limitations

Table 405.2 Maximum Ramp Slope and Rise for Existing Sites, Buildings, and Facilities

Slope ¹	Maximum Rise
Steeper than 1:10 but not steeper than 1:8	3 inches (75 mm)
Steeper than 1:12 but not steeper than 1:10	6 inches (150 mm)

1. A slope steeper than 1:8 is prohibited.

2024 Skulski Consulting LLC 78

78

Chapter 4 Accessible Routes
Ramps

- Handrails
 - Both sides for rise more than 6"
 - 1 1/4" to 1 1/2" diameter
 - 1 1/2" knuckle clearance from wall
- Edge protection
 - Ground surface extend 12" min beyond the inside face of handrails; or
 - Curb or barrier to prevent passage of 4" diameter sphere

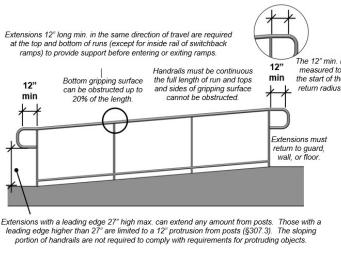

2024 Skulski Consulting LLC 79

79

Chapter 4 Accessible Routes
Curb Ramps (406)

- 1:12 max
- Counter slope of adjoining gutters and road surface no steeper than 1:20
- Flared sides for pedestrian cross traffic 1:10 max
- Should NOT project into vehicular traffic lanes, parking spaces or parking access aisles

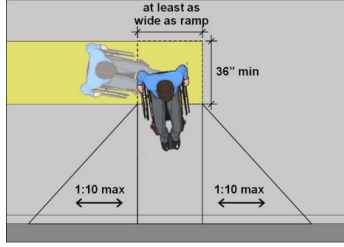

2024 Skulski Consulting LLC 80

80

**Chapter 4 Accessible Routes
Elevators (407)**

- Hall signals
 - Visible & audible signals
- Call controls
- Clear floor space
- Emergency 2-way communication

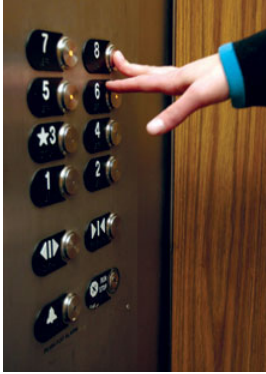

2024 Skulski Consulting LLC 81

81

**Chapter 5 General Site & Building Elements
Parking (502)**

- # spaces
- 8' min width for car
- 11' min width for van
- 5' min access aisle, adjacent to accessible route
- 1 of every 6 accessible spaces must be van accessible
- Universal 16' space preferred
- Signage

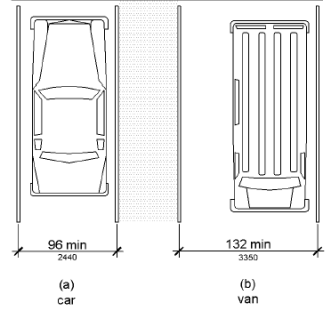

2024 Skulski Consulting LLC 82

82

NEW: A117.1 -- 2017

Accessible Routes Through Parking (507)

- Where accessible routes pass through parking facilities, they shall be physically separated from vehicular traffic.



2024 Skulski Consulting LLC 83

83

**Chapter 5 General Site & Building Elements
Stairways (504)**

- Stairs that are part of the means of egress
- Risers 4" to 7" height
- Tread width 11" min
- No open risers
- Handrails



2024 Skulski Consulting LLC 84

84

**Chapter 5 General Site & Building Elements
Handrails (505)**

- Located on both sides
- Continuous
- 34-38" height
- 1 1/2" between gripping surface and adjacent surface
- Cross section
 - Circular cross section with outside diameter of 1 1/4" to 2" max;
 - Non-circular cross section with perimeter dimension 4" to 6 1/4" and cross-section 2 1/4" max

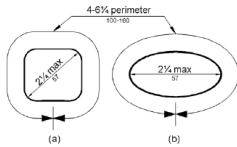

**Figure 505.7.2
Handrail Non-Circular Cross Section**

2024 Skulski Consulting LLC 85

85

**Chapter 6
Plumbing Elements & Facilities**

- Drinking fountains
- Toilet & bathing rooms
- Water closets & toilet compartments
- Urinals
- Lavatories & sinks
- Bathtubs
- Shower compartments
- Grab bars
- Seats
- Washing machines & clothes dryers
- Saunas & steam rooms



2024 Skulski Consulting LLC 86

86

Chapter 6 Plumbing Elements & Facilities
Drinking Fountains (602)

- Wheelchair accessible & standing access or single unit with dual access (hi-low combo)
- Where multi installations, 50% of each type
- Forward approach with clear floor space centered at unit
- Spout 36" height for low unit, 4" high water flow, 5" max from front of unit
- Spout 38-43" height for high standing unit
- Controls



87

NEW: A117.1 -- 2017

Bottle Filling Stations (602.4)

- Positioned for forward or parallel approach.
- Hand operated or automatic.
- Hand operated control within the reach range.

88

Chapter 6 Plumbing Elements & Facilities
Toilet Rooms (603)

- Clear floor space at toilet
- Turning space
- Door swing & maneuvering clearance at door



<https://www.access-board.gov/images/videos/toiletrooms-captioned.mp4>

89

Chapter 6 Plumbing Elements & Facilities
Toilet Rooms (603)

- Types of transfer
 - Side
 - Diagonal
 - Perpendicular

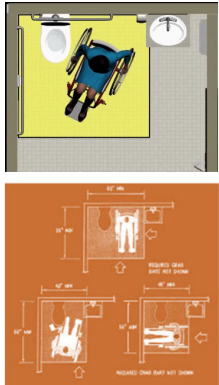

90

Chapter 6 Plumbing Elements & Facilities
Water Closets & Toilet Compartments (604)

- 60" min perpendicular from side wall
- 56" perpendicular from rear wall (59" for floor mounted toilets)
- 16-18" centerline
- 17-19" seat height
- Flush control located on open side of compartment

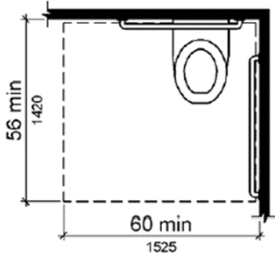

91

Chapter 6 Plumbing Elements & Facilities
Water Closets & Toilet Compartments (604)

- Clear floor space at toilet
- Turning space
- Door swing & maneuvering clearance at door
- Toe clearance for partitions

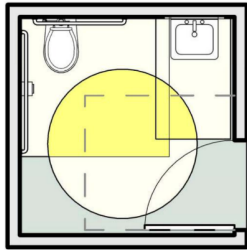

92

Chapter 6 Plumbing Elements & Facilities
Grab Bars in Toilet Compartments (604.5)

- Grab bars mounted at 33-36" height
- Side wall grab bar 42" min length, 12" max from rear wall, extending 54" min from rear wall

2024 Skulski Consulting LLC 93

93

Chapter 6 Plumbing Elements & Facilities
Grab Bars in Toilet Compartments (604.5)

- Rear grab bar 36" min length, extend from centerline of toilet 12" min on one side and 24" min on other side
- Exceptions
 - Recessed fixture adjacent to water closet
 - Location of flush control dictated by administrative authority – rear grab bar permitted to be split or shifted

2024 Skulski Consulting LLC 94

94

NEW: A117.1 -- 2017

Chapter 6 Plumbing Elements & Facilities
Vertical Grab Bars (ANSI A117.1 604.5.1.2)

- Vertical grab bars are not specified in ADA accessibility standards.
- ANSI A117.1 / State Codes
 - 18" minimum vertical grab bar at water closets.
 - Bottom of the bar located 39" min and 41" max above the floor, and with the center line of the bar located 39" min and 41" max from the rear wall.
 - ADA standards allow a second grab bar to be within the 12" clearance above the horizontal grab bar if there is a separation of 1 1/2" minimum.

2024 Skulski Consulting LLC 95

95

Chapter 6 Plumbing Elements & Facilities
Grab Bars in Toilet Compartments (604.5)

- Grab bars 33-36" high
- Circular cross section allows 1 1/4" to 2" outside diameter
- Non-circular cross section allows 2" max dimension and 4" to 4.8" perimeter
- 1 1/2" between wall and inside surface of grab bar
- Must withstand 250 lbs force

2024 Skulski Consulting LLC 96

96

Chapter 6 Plumbing Elements & Facilities
Dispenser (604.7)

- 7-9" in front of water closet, measured from centerline
- Outlet located between 15" and 48"
- Shall NOT be located behind grab bar
- Continuous paper flow
- 12" clearance above grab bar; 1 1/2" below grab bar

2024 Skulski Consulting LLC 97

97

NEW: A117.1 -- 2017

Toilet Paper Dispensers (604.7)

FIGURE 604.7.1(A) DISPENSER OUTLET LOCATION - PROTRUDING DISPENSER BELOW GRAB BAR

FIGURE 604.7.1(B) DISPENSER OUTLET LOCATION - PROTRUDING DISPENSER ABOVE GRAB BAR

FIGURE 604.7.1(C) DISPENSER OUTLET LOCATION - RECESSED DISPENSER

FIGURE 604.7.1(D) DISPENSER OUTLET LOCATION - DISPENSER IN FRONT OF WATER CLOSET - EXCEPTION

Where the dispenser is located below the grab bar, the outlet of the dispenser shall be located within an area 24 inches (610 mm) minimum and 42 inches (1067 mm) maximum from the rear wall.

Where the dispenser is located above the grab bar, the outlet of the dispenser shall be located within an area 24 inches (610 mm) minimum and 36 inches (915 mm) maximum from the rear wall.

Exception: Toilet paper dispensers that accommodate a maximum of 2 toilet paper rolls of not more than 5-inch diameter each shall be permitted to be located 7 inches minimum and 9 inches maximum in front of the water closet measured to the centerline of the dispenser. The outlet of the dispenser shall be 15 inches minimum and 48 inches maximum above the floor.

2024 Skulski Consulting LLC 98

98

Chapter 6 Plumbing Elements & Facilities
Ambulatory Accessible Toilet Compartment (604.8.2)

- Where 6 or more toilet compartments (or combined with urinals) are provided, 1 shall be an ambulatory
- 60" min depth
- 35-37" width
- Door shall not swing into minimum required compartment area
- Grab bars on both sides

2024 Skulski Consulting LLC 99

99

Chapter 6 Plumbing Elements & Facilities
Urinals (605)

- Where there are 2 or more
- Clear floor space position for forward approach
- Stall type or wall-hung with rim 17" high max
- 13 1/2" min deep measured from outer face of rim to back of fixture

2024 Skulski Consulting LLC 100

100

Chapter 6 Plumbing Elements & Facilities
Lavatories (606)

- Clear floor space for forward approach including knee and toe clearance
- 34" max height
- Exposed pipes & surfaces
 - Insulated or configured to protect against contact

2024 Skulski Consulting LLC 101

101

Chapter 6 Plumbing Elements & Facilities
Lavatories (606)

- Faucets
 - Within reach range
 - Operable with one hand and without twisting, pinching, grasping
 - Less than 5 lbs force to operate
 - Self metering faucets to remain open for 10 seconds min

2024 Skulski Consulting LLC 102

102

Chapter 6 Plumbing Elements & Facilities
Dispensers & Receptacles (205, 309)

- Soap dispensers
- Paper towel dispensers / hand dryers
- Trash receptacles
- At least one of each on accessible route
- Within reach ranges
- Meets requirements for operating mechanisms

2024 Skulski Consulting LLC 103

103

Chapter 6 Plumbing Elements & Facilities
Mirrors (603.3)

- Mirrors located above lavatories or countertops shall be installed with the bottom edge of the reflecting surface 40 inches maximum above the finish floor or ground.
- Mirrors not located above lavatories or countertops shall be installed with the bottom edge of the reflecting surface 35 inches maximum above the finish floor or ground.

2024 Skulski Consulting LLC 104

104

Chapter 6 Plumbing Elements & Facilities
Coat Hooks & Shelves (603.4)

- Coat hooks located within the reach range.
- Shelves, where provided, shall be located 40 inches minimum and 48 inches maximum above the finish floor.



2024 Skulski Consulting LLC

105

Chapter 6 Plumbing Elements & Facilities
Baby Changing Tables

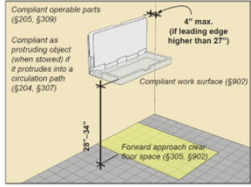

- If provided, at least one should comply with requirements for work surfaces and protruding objects.
- Baby changing tables cannot overlap fixture clearances or door maneuvering clearances when stowed.
- Clear space for a forward approach to the table is required. This space can overlap fixture clearances and door maneuvering clearances.
- Handle to pull unit open should not exceed 48" height
- Top of work surface 30-34"

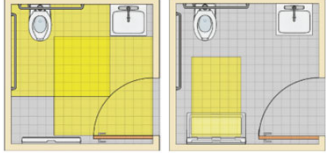

2024 Skulski Consulting LLC

106

Chapter 6 Plumbing Elements & Facilities
Bathtubs (607) & Showers (608)

- Size & clearances for transfer & roll-in
- Seats
- Controls & handheld shower spray
- Water temperature
- Grab bars



2024 Skulski Consulting LLC

107

Chapter 7
Communication Elements & Features

- Fire alarm systems
- Signs
- Telephones
- Detectable warnings
- Assistive listening systems
- ATM's & fare machines
- Two-way communication systems



2024 Skulski Consulting LLC

108

Chapter 7 Communication Elements & Features
Fire Alarm Systems (702)

- References National Fire Alarm Code
- NFPA 72 (1999 or 2002)
 - 110 db max
 - Flash rate & pulse duration
 - Location – wall & ceiling
 - Minimum intensity (based on coverage area)
 - Larger coverage area through fewer appliances
 - Many spaces (other than corridors) can be covered by 1 appliance



2024 Skulski Consulting LLC

109

Chapter 7 Communication Elements & Features
Signs (703)

- Identifying permanent rooms and spaces
 - Raised letters
 - Braille
 - Pictograms
 - San serif
 - Finish & contrast
 - Mounting location & height (height range based on bottom line of text)



2024 Skulski Consulting LLC

110

**Chapter 7 Communication Elements & Features
Signs (703)**

- Tactile signs required for:
 - interior and exterior signs identifying permanent rooms and spaces, where provided (§216.2);
 - required door labels at exit stairways, exit passageways, and exit discharge (§216.4.1);
 - required labels for floor levels, car controls, and emergency communication devices at elevators (§407.2.3.1, §407.2.3.2, §407.4.7.1.1, §407.4.9); and
 - rail station identification signs at entrances and platforms or boarding areas (§810.6.1).
- Signs that identify permanent rooms and spaces include:
 - room and floor numbers or letters;
 - room names; and
 - labels for restrooms, locker rooms, cafeterias, libraries, conference rooms, mechanical rooms, and other permanent rooms or spaces.



2024 Skulski Consulting LLC

111

**Chapter 7 Communication Elements & Features
Signs (703)**

- Raised characters and braille on signs
- Latch side of door
- Mounted 48" min above the finish floor or ground surface, measured from the baseline of the lowest tactile character, and 60" max above the finish floor or ground surface, measured from the baseline of the highest tactile character.

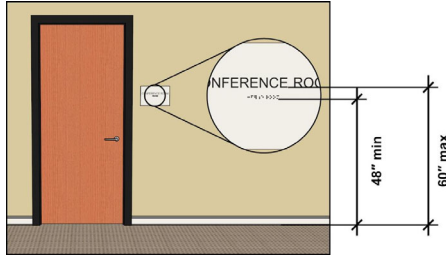

2024 Skulski Consulting LLC

112

**Chapter 7 Communication Elements & Features
Signs**

- Directional signage.
- Signage indicating location of accessible features when not all features are accessible.



2024 Skulski Consulting LLC

113

**Chapter 7 Communication Elements & Features
Telephones (704)**

- Applies to all public phones (including courtesy phones)
- 1 per floor/bank
- Clear floor space
- Operable parts located within reach range
- Hearing aid compatible
- Volume control
- TTY



2024 Skulski Consulting LLC

114

**Chapter 7 Communication Elements & Features
Detectable Warnings (705)**

- Required where a pedestrian circulation path meets a vehicular way (new PROWAG R208, 305) and at transit station boarding platforms
- Greater range of designs & products allowed
- Dome diameter (range)
- Spacing (range)

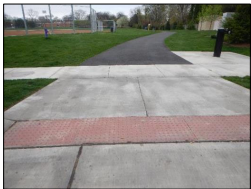

2024 Skulski Consulting LLC

115

**Chapter 7 Communication Elements & Features
Assistive Listening Systems (706)**

- Receiver jacks
- Hearing-aid compatible
- Receivers (neck loops)
- Sound pressure level
- Signal to noise ratio
- Peak clipping level



2024 Skulski Consulting LLC

116

Chapter 7 Communication Elements & Features
ATM's & Fare Machines (707)

- Speech output
 - Recorded or digitized
 - Privacy
 - Output instructions
 - User control (volume, repeat)
 - Operable parts (differentiation by sound or touch)
- Tactile features
 - Input controls
 - Numeric keys
 - Function keys
 - Braille instructions



2024 Skulski Consulting LLC 117

117

Chapter 7 Communication Elements & Features
Two-way Communication Systems (708)

- Visual and audible signals
- Handsets (cord length)
- Systems serving dwelling units (TTY)



2024 Skulski Consulting LLC 118

118

Chapter 8
Special Rooms, Spaces & Elements

- Assembly areas
- Dressing, fitting and locker rooms
- Kitchens and kitchenettes
- Medical care and long-term care
- Transient lodging
- Prison cells
- Courtrooms
- Dwelling units
- Transportation facilities
- Storage

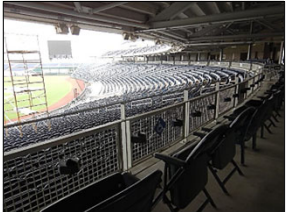

2024 Skulski Consulting LLC 119

119

Chapter 8 Special Rooms, Spaces & Elements
Assembly Areas

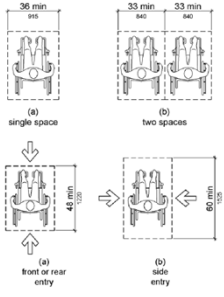

- Wheelchair seating locations
- Shoulder to shoulder companion seating
- Depth of space depends on approach from front/rear (48" min) or side (60" min).
- Accessible route shall not overlap area for wheelchair seating.
- Access to any wheelchair space cannot be through another wheelchair space.
- Line of sight.

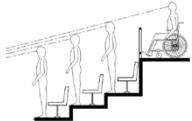

2024 Skulski Consulting LLC 120

120

Chapter 9
Built-in Elements

- Dining surfaces
- Work surfaces
- Check out aisles
- Service counters
- Dressing Benches



2024 Skulski Consulting LLC 121

121

Chapter 9 Built-in Elements
Dining & Work Surfaces

- Dining surfaces
- Work surfaces
- Top of surface 28" min to 34" max height
- Forward approach with knee and toe clearance = 17-25" depth



2024 Skulski Consulting LLC 122

122

Chapter 9 Built-in Elements
Sales & Service Counters

- Sales counters
- Reception
- Information
- Concierge
- Registration
- Check-out
- Admissions / ticket counters
- Customer service
- Ordering, pick up, drop off



2024 Skulski Consulting LLC

123

Chapter 9 Built-in Elements
Sales & Service Counters

- Access to one of each type / function
- Dispersed
- Countertop surface 36" max height, full depth of counter for customer use.
- Folding shelves not permitted in new construction or alterations.
- Allows for forward or side approach
- Forward approach shall include knee and toe clearance below counter.



2024 Skulski Consulting LLC

124

Chapter 10
Recreation Facilities

- Amusement rides
- Recreational boating facilities
- Exercise machines
- Fishing piers and platforms
- Golf facilities
- Miniature golf facilities
- Play areas
- Swimming pools, wading pools and spas
- Shooting facilities with firing positions
- Outdoor developed areas
 - Picnic areas
 - Trails
 - Campgrounds
 - Scenic viewing areas
 - Beaches





2024 Skulski Consulting LLC

125

UPCOMING: A117.1 – 2024-25

Adult Changing Stations (613)

- See also Plumbing Code for electrical hook up
- The room shall provide a soap dispenser, hand towel dispenser or hand dryer, coat hook, waste receptacle, signage indicating "Adult Changing Station," and signage with weight capacity and instructions for operation.
- Changing surface 30 x 70 inches
- Minimum 400 lb capacity
- Height adjustability 17 to 38 inches above the floor as measured to the top of the changing surface.
- Side maneuvering clearance 36 inches minimum.
- End maneuvering clearance 36 inches minimum depth at one end.
- Side rail capable of being raised and lowered

2024 Skulski Consulting LLC

126

UPCOMING: A117.1 – 2024-25

EV Charging Stations

- Minimum number that are physically accessible including the size of the vehicle charging space, providing access aisles, how and where the chargers are installed, and the physical operability of the charger.
- All EV chargers should have accessible communication features and operable parts.
- Access Board guidance <https://www.access-board.gov/ta/tad/ev/>

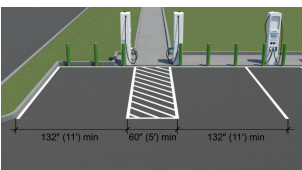

2024 Skulski Consulting LLC

127

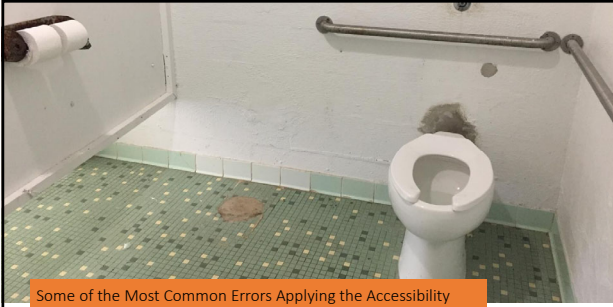

Some of the Most Common Errors Applying the Accessibility Standards to New Construction and Existing Facilities

- Misinterpretation of the standards
- Trying to take the "easy way out"
- Misuse of "grandfathered"
- Misuse of "technically infeasible"
- Claiming "construction tolerances"

2024 Skulski Consulting LLC

128

City of Mobile
Most Frequently Cited Recommendations

1. Modify existing pathway (86)
2. Adjust door opening force (interior doors) (85)
3. Add/replace drinking fountain with high-low unit (68)
4. Adjust door opening force and/or evaluate for auto/power door (exterior doors) (58)
5. Provide picnic units with mobility features (58)
6. Provide accessible routes to sports field/court (57)
7. Install/remount restroom identification signage with braille and raised characters (57)
8. Correct changes in level/openings for accessible route (51)
9. Provide integrated accessible seating in spectator viewing area (49)
10. Provide accessible route to team seating areas (46)

129

Exceeding the Minimum Standards

- Understand the rationale behind the scoping and technical provision.

	Accessibility Standards MAX	NPS - Denver Service Center MAX	Dimensional Tolerances Study (Ballast)
Accessible Routes	1:20 = 5%	1:21.0 = 4.75%	1:25 = 4%
Ramps	1:12 = 8.33%	1:12.5 = 8%	1:13 = 7.5%
Parking or Cross Slopes	1:48 = 2.08%	1:55.0 = 1.8 %	1:67 = 1.5%

146

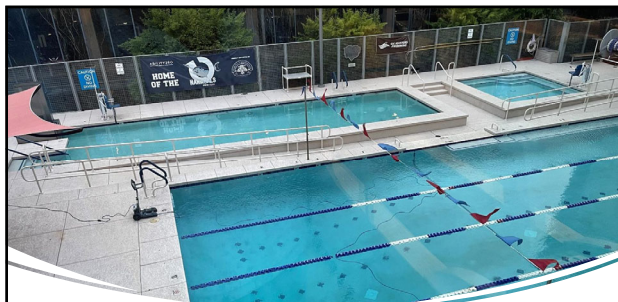

Exceed the Minimum Standards

- Accessibility standards should be considered at the beginning of the planning process, not as add-ons at the end of the design.
- Seek opportunities to apply the principles of universal design.
- Design for inclusion.

147

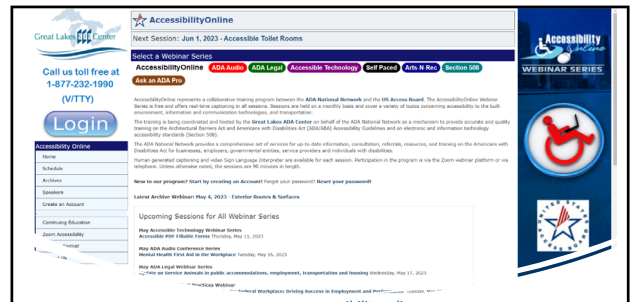

Seek Continuing Education on the Accessibility Standards

- www.accessibilityonline.org
- Presented monthly by the U.S. Access Board & the Great Lakes ADA Center
- Free sessions, archives on-demand
- National ADA Symposium
- Presented by the Great Plains ADA Center and the National ADA Network
- www.adasymposium.org

148

Technical Assistance

U.S. Access Board

- www.access-board.gov
- (202)272-0080 extension 3

U.S. Department of Justice Disability Rights Section

- www.ada.gov

149

Jennifer Skulski
 Skulski Consulting LLC
 (317) 408-4427
jennifer@skulskiconsulting.com
www.accessibilitymanagementnews.com

150